

COLUMN REF.	SIZE.(mm)
A	450 x 250
B	450 x 200
C	580 x 200
D	1035 x 250
E	250 x 250
F	875 x 250
G	300mm DIA.
H	1330 x 200

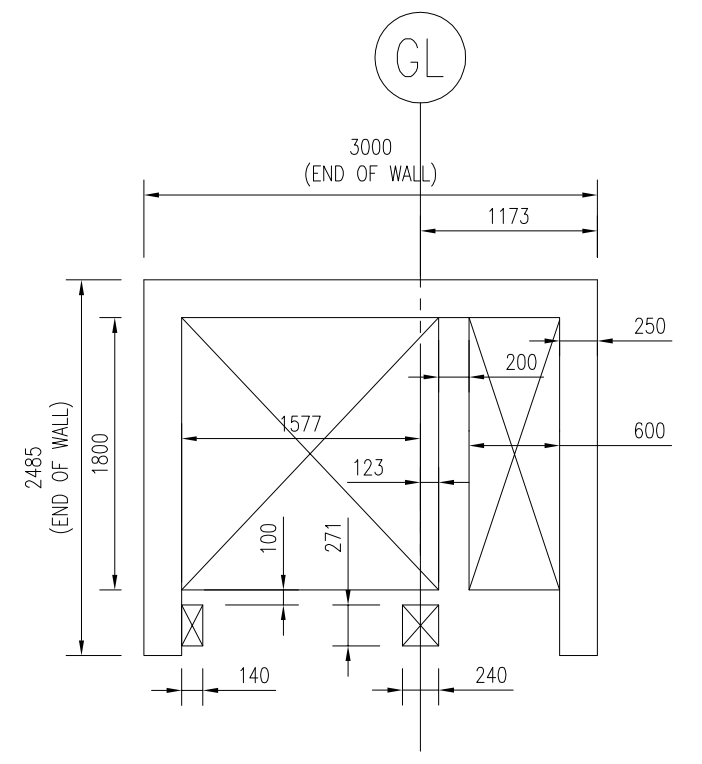

TYPICAL CORE SETTING OUT

- NOTES:**
- GENERAL
 - This drawing is not to be scaled, work to figured dimensions only, confirmed on site.
 - This drawing is to be read in conjunction with all relevant architectural drawings, detailed specifications where applicable and all associated drawings in this series.
 - Any discrepancy on this drawing is to be reported immediately to the partnership for clarification.
 - The contractor is responsible for all temporary works and for the stability of the works in progress.

NOTE:
 DIMENSIONS GIVEN ARE TO CENTRELINE OF COLUMN FROM GRIDLINE UNLESS NOTED OTHERWISE.
 COLUMNS AT GROUND FLOOR SHOWN FULL LINE.
 COLUMNS AT OTHER LEVELS SHOWN DASHED LINE.
 STG INDICATES DIMENSION TAKEN FROM SLAB EDGE TO GRIDLINE.

Revision	Date	By	Rev. No.
DRAWING TITLE REVISED, SLAB EDGE DIMENSIONS AND TYPICAL CORE DETAIL ADDED.	14-07-2000	M.PACIFICO	C
CORE C AMENDED	12-06-2000	M.PACIFICO	B
9No. COLUMNS: A2,B2, B4,C4 & C5,D6 MOVED	28-04-2000	M.PACIFICO	A
FIRST ISSUE	03-04-2000	M.PACIFICO	

Client: **BERKELEY HOMES (SOUTHERN) LTD**

Project: **24-30 MARINE PARADE
BRIGHTON, EAST SUSSEX**

Title: **COLUMNS, CORES & SLAB EDGE SETTING OUT**

HEMSLEY ORRELL PARTNERSHIP
 CONSULTING CIVIL & STRUCTURAL ENGINEERS

● HOP HOUSE, 41 Church Road, Hove, East Sussex BN3 2BE
 Tel : (01273) 223900 Fax : (01273) 326767 Email : hophouse@dal.pipex.net

○ 151 Western Road, Hove, East Sussex RH16 3LH
 Tel : (01444) 457756 Fax : (01444) 455953 Email : hop.h@virgin.net

Project No.	Task No.	Dwg. No.	Rev. No.
8459	02	108	C